

**KUNDIG**



**The Sanding Experts**



**Swiss company KUNDIG** specializes in producing high end edge- and wide-belt sanders as well as brushing machines. Thanks to more than 75 years of experience in sanding technology and thousands of machines sold world wide, the enterprise has a great deal of expertise in this field and is able to provide individual solutions for almost every requirement. KUNDIG has its headquarters in Wetzikon (Zurich, Switzerland). Thanks to our partner companies and wholly-owned subsidiaries in Germany, Austria, France the USA and Great Britain we provide a world-wide sales and service network.



Lukas Kündig - CEO Kündig Group



## Content

### Part 1: Widebelt Sanders

This is why Professionals choose Kündig

Our Oblique Sanding Technology

ECS - Eco Cleaning System

The operating concept

Sanding Units - An Overview

*Master Series*

*Perfect Series*

*Technic Series*

#### Applications

Industry applications

Top-Bottom-Sanding

High precision sanding

Brushing

Cross-sanding

04

04

05

06

07

08

12

14

16

18

18

19

19

20

21

Timber construction

Planing

Cross-Grain Sanding

Window Sanding

Practical examples / Special Materials

Accessories for our wide belt sanders

### Part 2: Edge Sanders

Model comparison - *Uniq Uniq-S Flash*

Sanding units - 4 sanding stations

Sanding unit - Oscillation

Sanding unit - Inclination

Feed system of *Uniq-S* and of *Flash*

Kündig Flash - the details

Accessories for our edge sanders

### Part 3: Lifelong enjoyment

22

22

23

23

24

26

28

29

30

30

31

32

32

34

35

# This is why Professionals choose **KUNDIG**

## **Robust Construction, modular Design**

Sanding machines from KUNDIG have proven themselves worldwide in decades of use and under the toughest conditions. Our sanding systems master challenges such as permanent stress in three-shift operation environments, the sanding of particularly abrasive materials (such as carbon fiber, foam glass or silicon carbide) or the load of workpiece weights of 1000 kg / 2000 lb and more. Thanks to the use of high-quality components and generously dimensioned welded steel construction with particularly high material thicknesses throughout, high precision and sanding quality is guaranteed even after years of hard use. The modular design allows putting together the ideal machine for each customer according to his individual requirements. The units can be freely selected, just like the working width and the accessories.

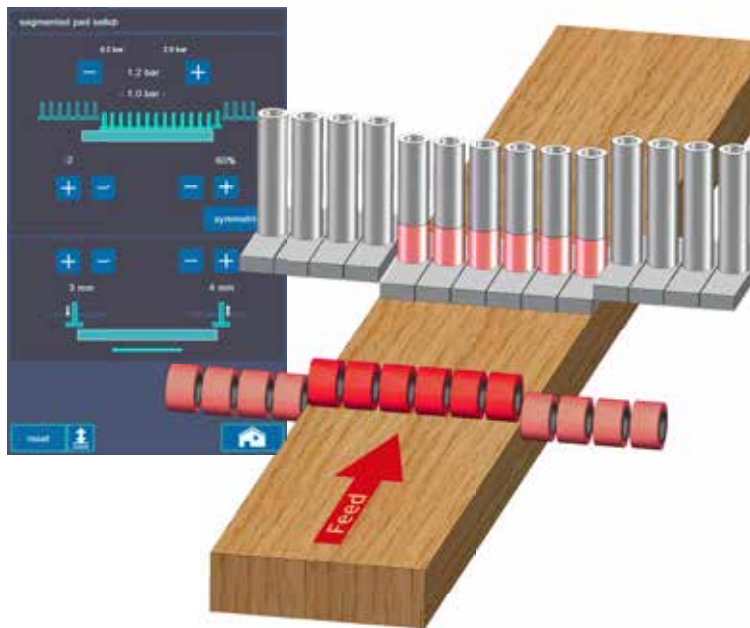

## **Cutting Edge Segmented Pad Control Technology**

In our machines, the detection rollers, as well as the fine sanding pad's segments share the same 22 mm (0.86") width. This tool, trimmed for maximum performance in terms of precision and dynamics, is reduced to such a clear and deliberately simple user interface so that, in the event of a special requirement, the operator can achieve the desired result intuitively and in mere seconds. Corrections to the pressure or edge area behavior both laterally and on the infeed and outfeed side are immediately visible to the operator on the display by means of schematic representation. The **HSS, High Speed Segment Technology** achieves maximum performance in reaction and contact pressure behavior thanks to uncompromising in-house development of the hardware and software of our control electronics as well as the segments themselves. Thus, the system fulfills the requirements for problem-free sanding of difficult surfaces, even at extremely high feed speeds of up to 100 m/min (330 ft / min).



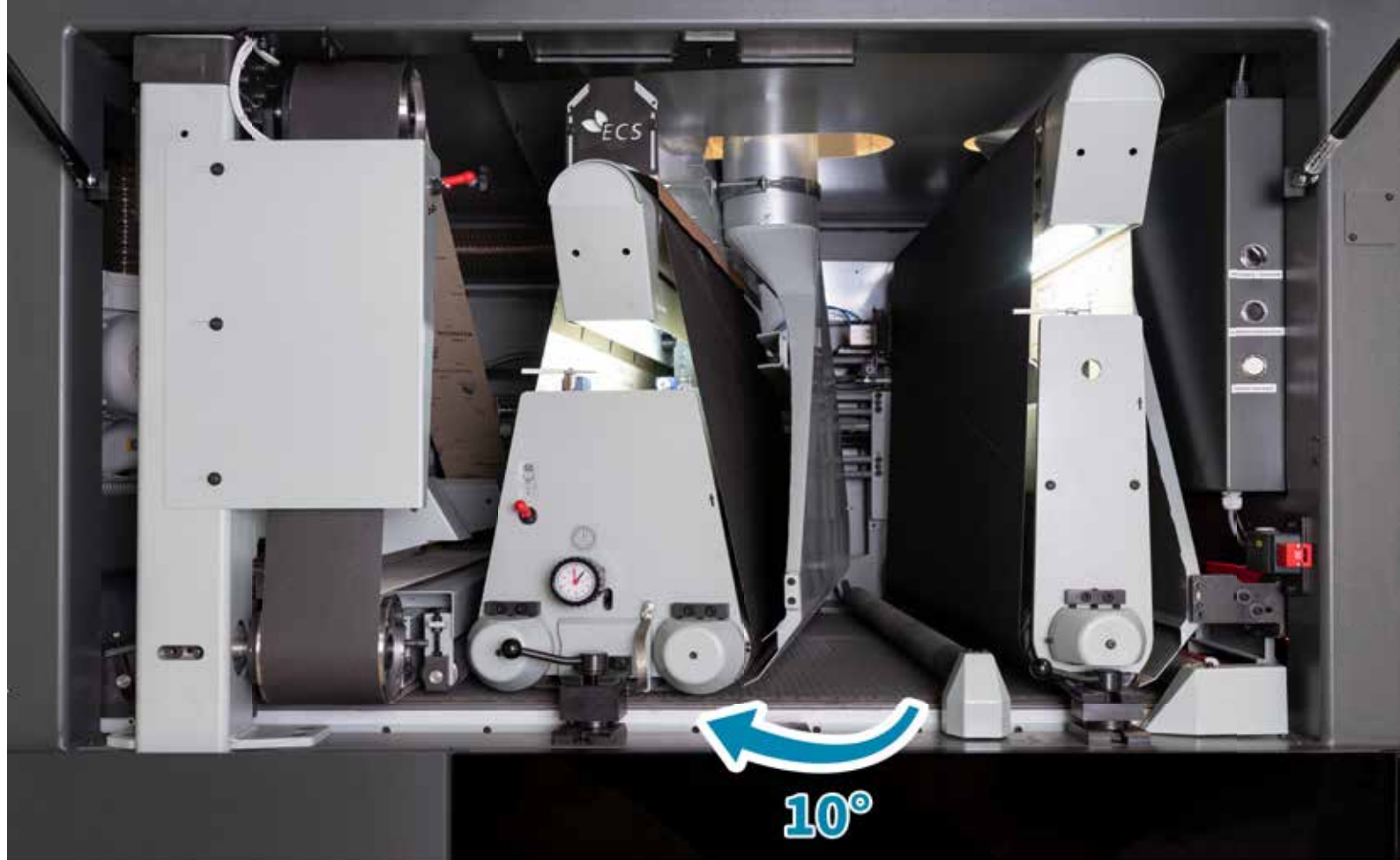

## Our Oblique Sanding Technology

Ingeniously simple, patented and well-proven

In conventional sanding, abrasive belt defects, such as protruding abrasive grains or grit breakouts, always move parallel to the feed and therefore always run at the same position over the length of the workpiece, which creates undesirable oscillation marks. With oblique (diagonal) sanding, on the other hand, the sanding belts rotate at a slight angle to the feed and are therefore never engaged at the same point. The oscillation marks „fade“ on the workpiece surface. The result is a significantly improved surface quality.

This superiority of the oblique sanding process has been scientifically proven at the IHD (Institut für Holztechnologie Dresden) and has clear advantages over conventional parallel sanding: Abrasive belt consumption is reduced dramatically. This is because wear and tear to the sanding belts, as well as the naturally varying size of abrasive grains, do not appear on the surface until much later. There's also fewer raised fibers and less heat development during sanding and a noticeably better surface quality on lacquer, veneer or finely sanded solid wooden parts, as well as workpieces with changing fiber direction.

### The Advantages

- Absolutely homogeneous surfaces
- No oscillation traces
- No raised fibers
- Significant reduction of scratches on cross grain workpieces
- Reduction of sanding belt consumption of up to 35%
- Less lacquer consumption due to the absence of raised fibers
- Greatly improved surface quality
- Easy handling

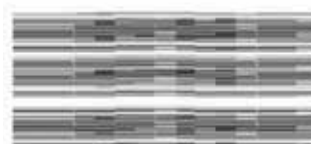
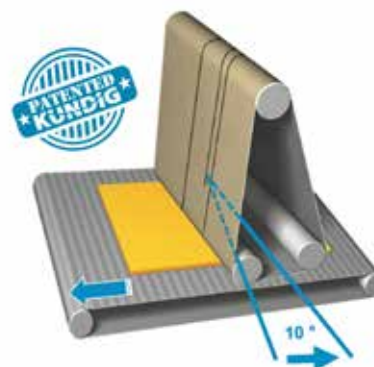

Parallel



Diagonal





## ECS - Eco Cleaning System

Save costs, optimum belt cleaning, patent pending

In order to keep the sanding quality at the highest level and at the same time optimize the life of the sanding belts, the sanding belt must be cleaned as continuously as possible from adhering dust from the sanding process. Conventionally, this is achieved by blowing off the sanding belt using compressed air. These methods usually work selectively and therefore clean the sanding belt unevenly, which is reflected in an irregular sanding pattern, especially with delicate materials. Compressed air is also the most expensive form of energy in a company and must be used as sparingly as possible or even avoided completely.



To massively reduce these costs in daily operation, Kündig has developed the  ECS technology. Here, a so-called air blade discharges a continuous stream of air that cleans the sanding belt and, if required, the workpiece without the need for expensive compressed air. Instead, the air flow is provided by an efficient motorized fan. The air blade works across the entire working width of the machine and therefore cleans evenly and efficiently. The efficiency is around twice as high as with simple compressed air cleaning.

The system becomes even more efficient if the same fan is used for both, the  ECS system and for generating the vacuum in the transport carpet by using a switch.

Apart from the fan, which is protected in the machine body, the  ECS does not involve any moving parts and is therefore maintenance-free and durable. At the same time, the air blade is enclosed by an extraction hood so that the blown-off dust and workpiece particles are fed directly to the central extraction system without contaminating the machine.

Due to the increased energy efficiency of  ECS, the Kündig sanding machine has been recognized as eligible for subsidies in some countries. Kündig has applied for a patent for this highly efficient and cost-effective system and more than 100 systems are already in use worldwide.

### Advantages at a glance

- Optimal surface quality
- No undesired sanding tracks („Snake lines“)
- Longer life of sanding belt
- Increased workpiece cleaning
- Massively reduced energy costs - ROI approx 1.5 years at best
- Reduced noise level in production
- Combination with ionisation for workpiece cleaning possible



# Everything under Control - The Operating Concept



**Full Control** means that everyone in the workshop, young or old, apprentice or master, after a very short amount of time and completely by themselves, uses all of a machine's functions down to the last detail. This is why we at KUNDIG have always given top priority to equipping our sanding machines with an operating concept that is not only logical and appealing at first glance, but also motivates the user to explore further options and thus achieve the maximum sanding quality on every surface.

## Control System features

- 1-Click Quick Start
- Logical, clear, time-saving
- Remote access via network or cloud
- Recording of production data, e.g.: m<sup>2</sup>/ft<sup>2</sup> measurement and job times
- USB port for data backup
- USB port for devices
- Automatic error diagnosis with guided trouble-shooting
- Integrated PDF documentation (wiring diagram, instructions, sanding advice)
- 10 – 19" screens available



## Remote Access

- With different devices (smart phone, tablet, pc, etc.)
- Remote controlling of the machine
- Trouble shooting / diagnosis
- Support
- Data logging through cloud
- Software updates & backups
- High security thanks to VPN
- Connection to all relevant control systems, in particular the Industry 4.0 standard OPC UA

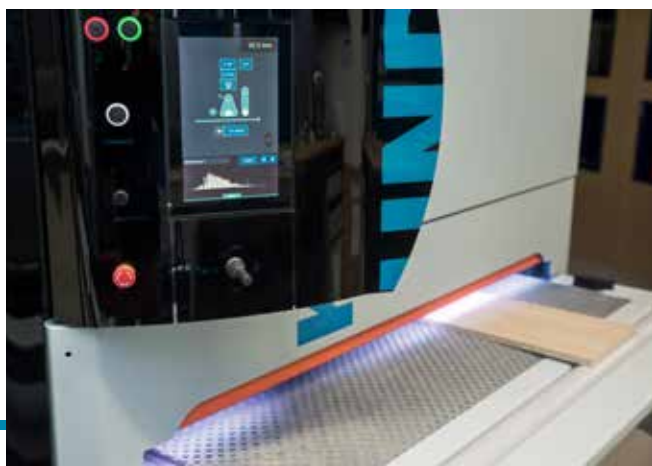

## ENORMATIC - Sanding doesn't get much easier

Select sanding parameters, press **ENORMATIC** button, insert workpiece. The machine now measures the workpiece over the entire working width, detects its edges and automatically carries out the complete sanding process. For repetitive sanding jobs, programs can also be stored and called up in just seconds. Everyday sanding operations can be saved in the „Quick“ menu and accessed with just one click. Once the program is selected, simply insert the workpiece, everything else happens automatically.

# The perfect *Sanding Unit* for each Task

Sanding machines from KUNDIG can be equipped with a wide range of units. The choice and combination of sanding units is determined by the application area, throughput rates and surface requirements. The individual sanding units also offer different equipment variants to guarantee perfect adaptation to all the individual requirements of each user.

## 1 Calibration Roller (R)

Proven calibration roller for precision calibration tasks.

Steel or rubber versions (different hardnesses) available

Also available with our oblique sanding technology

Also available with automatic grain compensation

Also available as bottom sanding version

Models: *Master, Perfect, Technic*

## 2 Large Calibration Roller (G)

Proven calibration roller for precision calibration and fine sanding tasks

Steel or rubber versions (different hardnesses) available

Also available with our oblique sanding technology

Also available with automatic grain compensation

Also available as bottom sanding version

Models: *Technic*

## 3 Sanding Pad Unit (P / E)

Pneumatic or segmented sanding pad usually used for fine sanding, veneer or lacquer tasks

35 mm (1.37") or 22 mm (0.86") segments, High-Speed Technology

Also available with automatic grain compensation

Also available with our oblique sanding technology

Also available as bottom sanding version

Models: *Master, Perfect, Technic*

## 4 Combined Unit (K / C)

The Allrounder. It combines the Features of the calibration roller 1 and the sanding pad unit 3

Features calibration roller (see 1) and pad unit (see 3)

Also available with automatic grain compensation

Also available with our oblique sanding technology

Also available as bottom sanding version

Models: *Perfect, Technic*



1



2



3



4



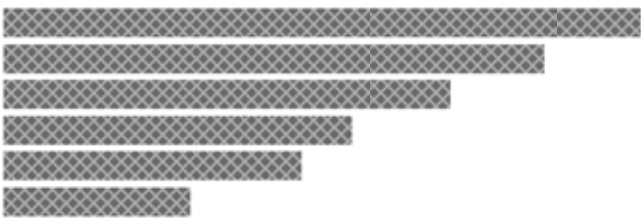

## Working Widths

There's a wide range of working widths available, depending on model range. Standard sizes are 650 mm (26"), 1100 mm (43"), 1350 mm (53") and 1600 mm (63"). Optionally up to 2200 mm (87"). Custom sizes are available.

## Belt Lengths

Sanding units **1 - 4** are available with larger belt lengths in our *Technic* series machines. Standard is 1900 mm (75") 2000 mm (79"), upgrade sizes are 2620 mm (103") and 3250 mm (128"). Custom sizes are available.



## 5 Cross Belt Unit (X / H)

Cross sanding technology in different versions for sanding cross veneer, lacquer up to high gloss or creating a rough sawn finish. For more details, see cross sanding (page 21)

At machine inlet, in between sanding units or at outlet

22 mm (0.86") width segments, High-Speed-Technology

Chevron conveyor belt with individual belt speed

Also available with our oblique sanding technology

Models: *Perfect, Technic*

## 6 Planing Unit (M)

Cutter head available in different variants used for very high stock removal of up to 15 mm (0.6")

Different cutter inserts available (Castor / Torsa)

Cutter head can be easily lifted out of machine for cutter exchange

Also available as bottom sanding (planing) version

Models: *Technic*

## 7 Brush Roller Unit (Bs / Bo)

Brushes either as accessories or machine body integrated units in great variety and for different purposes. For details see brushes (page 20)

Different sizes and materials (brass, nylon, horse hair)

Different applications ( sanding, texturing, cleaning)

Height adjustment either automatic or manual

Oscillating or non-oscillating versions available

Models: *Master, Perfect, Technic*

## 8 Disc Brush Unit (Bk)

Brushing or sanding unit with rotating disc brushes for sanding of cross grain sections, indentations and rounding of edges. For more details see cross grain sanding (page 23)

Easy bristle exchange

Large selection of bristle/sanding paper inserts

The brushes rotate, the whole unit oscillates

Models: *Technic*

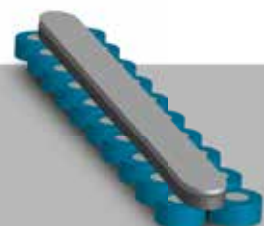
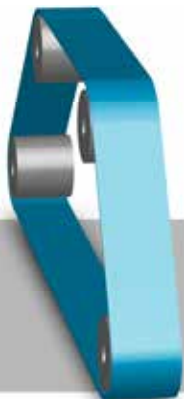

5

6

7

8

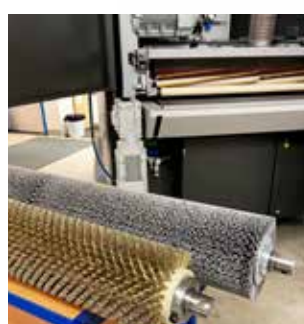



follow **KUNDIG** on







The *Master* gets to the heart of sanding. It contains the essence of our more than 75 years of experience in the field of sanding technology. This means that selected machine configurations that have proven themselves in thousands of woodworking companies around the world offer all the features that are essential for the fast, reliable production of perfect surfaces.



- Fixed work table and therefore constant table height
- Maximum workpiece thickness 200 mm (8")
- Infinitely adjustable stock removal
- Infinitely variable feed speed
- Workpiece thickness measurement over the entire working width
- 10" Sigmatek touch screen
- Probably the most advanced control system on the market
- Industry 4.0 capable
- Quick Start Programs (save and recall)
- **ENORMATIC** (automatic sanding)
- Eco\* Energy saving mode
- Belt length: 2000 mm (79")
- Working width: 1350 mm (53")
- Motorized roller adjustment for grain compensation
- Segmented sanding pads
- Sanding pressure control via touch screen



Configuration examples

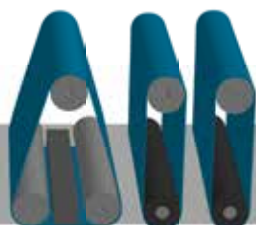



With their *Perfect* model range, KUNDIG is two steps ahead of the constantly changing interior design branch. Behind the modern design lies a multitude of innovations in sanding technology, which in combination exceed even the highest demands in terms of surface quality. The control unit, which has been developed from scratch, makes sanding even easier and more intuitive. All our models are suitable for integration into any relevant control system and are therefore fully capable of industry 4.0. Of course, the *Perfect* is completely modular and can be equipped with a large selection of sanding units and options.



- Patented oblique sanding technology for excellent sanding quality and significantly reduced abrasive consumption
- Fixed work table and therefore constant table height
- Maximum workpiece thickness 200 mm (8")
- Highly efficient table vacuum (adjustable)
- Infinitely adjustable stock removal
- Infinitely variable feed speed
- Electronic grain compensation and stock removal distribution across several contact rollers
- Automatic pressure control for segmented sanding pads
- Workpiece thickness measurement over the entire working width
- 10" touch screen
- 90° pivoting control panel
- Probably the most advanced control system on the market
- Industry 4.0 capable
- Quick Start Programs (save and recall)
- **ENORMATIC** (automatic sanding)
- Eco\* Energy saving mode
- Belt lengths: 1900 mm (75"), 2000 mm (79"), 2620 mm (103")
- Working widths: 1350 mm (53"), 1600 mm (63")

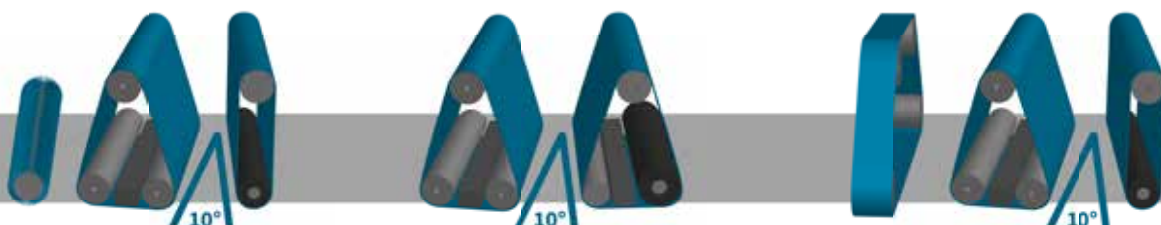
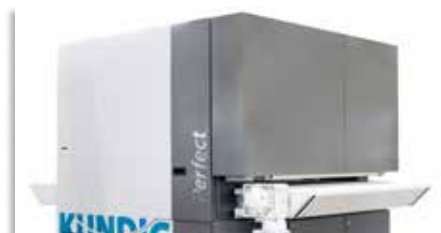

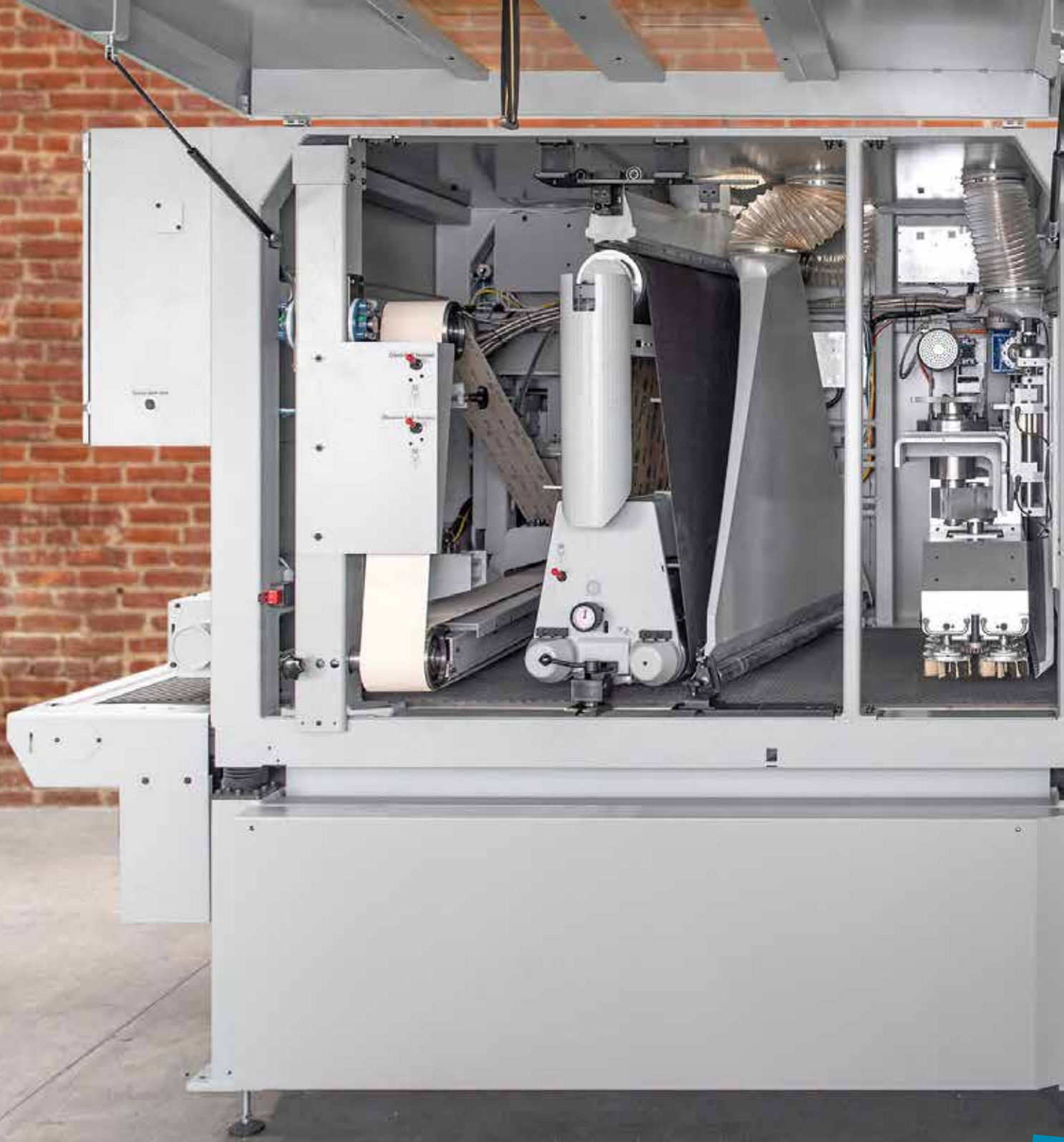

This *Technic-6* is one of many impressive examples of how the customization potential of the *Technic* range is also being used by interior fitting companies as an opportunity to position themselves on the market with a versatile range of surface finishes.

**KUNDIG** *Technic*



The machines of our *Technic* series allow the highly individual design of your personal sanding system. Whether high-quality interior fittings, continuous operation in the furniture industry, high-gloss lacquer in the production of concert grand pianos, the calibration of abrasive carbon fiber parts or the heavy workpiece weights in timber engineering: Thanks to decades of experience with the most diverse challenges in the field of sanding, we will work with you to find your personal solution for the perfect surface. The modular design allows us enormous flexibility in configuration using standardized, proven assemblies. If a suitable solution does not yet exist for a specific requirement, our experienced engineering department is able to develop specialized solutions through to complete custom-made products.



# Industrial applications

It is a series of factors which demand everything from machines in companies with particularly high throughput rates. Sanding machines from KUNDIG have the robust construction in their DNA, and even our standard models show hardly any loss of precision after decades of use. For particularly intense use, we offer our **Technic** series sanders. Thanks to many years of experience and numerous customization options, these machines can be tailored exactly to the individual requirements of each customer.



## Robust design

Sanders of the **Technic** series are characterized by their ability to maintain precision despite heavy loads. Since the type of stress can vary greatly, these sanding machines are individually adapted to it. Examples of different types of stress are:

- Three or four-shift continuous operation
- High feed rates
- The sanding of abrasive materials, such as carbon fiber or silicon carbide
- Permanent calibration with large stock removal and associated high motor power
- Particularly high workpiece weights and thicknesses



## Features and Options

### Various dimensions available:

Working Widths: 650 mm (26"), 1100 mm (43"), 1350 mm (53"), 1600 mm (63"), 1900 mm (75"), 2200 mm (87")

Belt lengths: 1900 mm (75"), 2000 mm (79"), 2620 mm (103"), 3250 mm (128")

**Integration into production lines:** Through e.g. adjustment of working height, special feed or handling tables and control interfaces according to industry 4.0 standards

**Reinforced sanding units:** Special designs are available for most units, with larger deflection and contact rollers, modified unit mounts or specially encapsulated bearings. This also applies to bottom-sanding variants

**Significantly reduced energy consumption:** ...thanks to intelligent control electronics, our lightweight **high-speed segments** and the **ECS Eco Cleaning System**, which allows belt and workpiece cleaning without compressed air consumption.

**Accessories:** Very large selection of accessories and individualization opportunities





## Top-Bottom-Sanding

With our **Technic Botop** series wide belt sanding machines, the top and bottom sides of workpieces can be sanded in just one pass. This saves time and effort, which would be required to perform several sanding operations. These systems are very popular with panel production, veneer processors and stair construction companies, for example. With our **Side-2-Side** sanding systems the left and right sides of the workpiece are processed (Third image on the right). Coupled with a **Technic Botop**, all four sides of the workpiece can therefore be sanded in just one pass.

- Basically the same equipment details as for all other machine series. Most units and options are also available in bottom sanding machine bodies.
- For special sanding applications, pure bottom sanding systems can also be supplied.
- Working widths: 650 mm (26"), 1100 mm (43"), 1350 mm (53"), 1600 mm (63"), 1900 mm (75")
- Belt lengths: 1900 mm (75"), 2000 mm (79"), 2620 (103")



## High precision sanding

We offer a range of machine types that are specially designed for the precise calibration or fine sanding of various materials. Depending on the application, different equipment is required. For example, high-precision units, special conveyor belts or optimized height adjustment components are installed. Some examples of precision applications are:

- Calibration of laminate materials HPL/CPL (tolerances up to  $\pm 0.005$  mm)
- Sanding of honeycomb sandwich panels (tolerances up to  $\pm 0.01$  mm)
- Sanding of veneer, also top/bottom (tolerances up to  $\pm 0.01$  mm)
- Many other materials such as plastics and composites, rubber belt, cork from a roll, (see practical examples on page 25)
- Working widths and belt lengths depend on the application type





## Brushing

KUNDIG offers a wide range of solutions for the texturing of surfaces. In most cases, brushes are the means of choice. These are available as an additional unit in wide belt sanding machines, either integrated in the machine body or mounted at the machine outlet. Dedicated brushing machines are also part of our product range.



### Add-on Structure Brush Unit

The add-on unit at the machine outlet is ideally suited to supplement the application field of a wide belt sanding machine with structured surfaces. The exchangeable brush is available in different materials and configurations. You can choose between electronic and manual height adjustment in order to compensate for brush wear and define brush immersion depth.

Working widths: 650 mm (26"), 1100 mm (43"),  
1350 mm (53"), 1600 mm (63")

### Machine Body integrated Solutions

Machine body integrated brushing solutions are particularly aimed at companies that texture wood on a regular basis. Such solutions represent an uncompromising combination of brushing machine and sanding machine. The brushes are available with or without oscillation, in different sizes and materials.

Working widths: 650 mm (26"), 1100 mm (43"),  
1350 mm (53"), 1600 mm (63")



### Brushing Machines

KUNDIG also offers complete brushing machines. These are often found in industrial parquet production. The possibilities for individualization are very diverse. Here too, brushes are available in various materials, types and sizes, as well as with and without oscillation. The machines are precisely matched to their area of application. Top/bottom brushing machines are also available.

Working widths: 650 mm (26"), 1100 mm (43"), 1350 mm (53")  
1600 mm (63"), 1900 mm (75")

Ø Brushes (mm): 120, 180, 200, 220, 250, 300

Standard drive power: 5.5 kW to 22 kW





For certain applications, a cross sanding unit proves to be the perfect choice. For example, an unparalleled finish can be achieved on cross-veneered or high-gloss lacquered parts, especially in combination with our patented oblique sanding technology. For this purpose we offer a selection of different cross belt units, alternatively integrated in the machine body or at the machine exit.

### High Gloss Sanding Unit H and Hg

The cross belt unit, also called high gloss unit, mounted at the machine outlet is especially suitable for sanding lacquer layers up to high gloss applications. Thanks to decades of experience and constant further development, the high-gloss unit combines a range of technologies that make it the first choice of surface specialists with the highest demands:

- Highly efficient segmented sanding pad with segments 22 mm (0.86") wide featuring our advanced segmented pad control technology (see page 4)
- The sanding belt is driven by a lamella support belt, also called chevron belt.
- The speeds of the sanding belt and the chevron belt can be adjusted individually in order to modulate the sanding track length.
- Lift-off technology: This so-called pre-insertion avoids the well-known problem of workpieces colliding with abrasive belts warped by moisture.
- For ultra-high-gloss applications (e.g. surfaces of concert grand pianos) the cross belt unit Hg with extra long sanding belt (7000 mm / 275") is available.
- Working widths: 1350 mm (53"), 1600 mm (63"), 1900 mm (75")
- Belt lengths: 5250 mm (207"), 5650 mm (222"), 6200 mm (244"), 7000 mm (275")

### Cross Belt Unit X, Xi and Xg

The cross belt unit X is mounted at the machine inlet, outlet or inside the machine body. It is suitable for production of high-quality surfaces up to lacquer and works best in combination with our oblique sanding technology. Further applications are the sanding of cross grain or cross veneered parts and/or the technical pre-sanding, i.e. the removal of plastic and glue residues, or the cleaning of workpieces. Like the high-gloss unit H, it is equipped with a lamella support belt, infinitely variable belt speed and the pre-insertion feature to avoid crashes with the workpiece when sanding belts are warped due to moisture.

**H** Unit



**X** Unit



**Hg** Unit



# Timber Construction



# Planing



The sanding machine is no longer an exotic sight in carpentry or timber construction. The requirements for the surfaces often go far beyond „planed“ or „sawed“. All of our sanding machines are suitable for very high workpiece weights and loads. However, we do offer some customizations that make them even more ideal for timber construction.

- Workpieces up to 1000 kg (2000lb) in standard machine frame, optionally even more
- Extension of the passage height up to 800 mm (32") for extremely thick workpieces
- Reverse feed feature to avoid lifting of heavy parts out of the machine when multiple sanding operations are necessary
- A selection of planer heads with different cutter configurations is available.
- A selection of brushing/texturing solutions is available.



Timber construction companies, staircase manufacturers, panel processors, coffin factories and plastics producers rely on the advantages of our planer sanding systems for high chip removal rates.

- **Working width:** A significant advantage compared to conventional planers is the larger working width. The installation of cutterheads up to 1600 mm wide is our standard. Depending on the application and machine design, more is also possible.
- **Flexibility:** Another advantage of the planer sanding machine, thanks to the combination with sanding units, is that more work steps and thus a finished, finely sanded surface can be produced in one pass. This also applies to top-and-bottom sanding systems.
- **Efficiency:** Furthermore, planing is more time and energy efficient than sanding at a certain chip removal. Chip removal of up to 10 mm on solid wood can be achieved, which usually eliminates the need for several sanding passes.

Planer heads are available from well-known manufacturers, optionally with continuous longitudinal blades or with turn blade knives.



## Cross Grain Sanding

With their disc brush unit, which is available as part of KUNDIG's range of wide belt sanders, the Swiss company found a reliable solution for cross grain sanding that perfectly eliminates scratches on cross grain areas of wooden workpieces such as kitchen doors. This is best achieved in combination with their patented oblique sanding technology.

Another application of our disc brush unit, thanks to its specialized movement pattern, is rounding off workpiece edges very consistently and evenly. Meaning that all of the workpieces edges will end up with the exact same radius. Furthermore, the disc brush unit can be used for intermediate filler or lacquer sanding on profiled and even workpieces.

The disc brush unit is equipped with 24 rotating 5" discs. Both the unit's oscillation as well as the disc rotation can be steplessly adjusted in order to achieve the best possible surface finish.



## Window Sanding

The engineers at KUNDIG have developed the „Vmax“ principle, which solves the challenges of sanding window frames. Two oblique units arranged in a V-shape ensure that the crossbar of the window frame never hits the sanding unit at a right angle. The technology has proven itself over the last 15 years at numerous window manufacturers. There are several advantages:

- Window frames sanded with this technology show no raised fibers after coating. This means that hardly any intermediate sanding is necessary before the varnish is applied.
- No right-angled collision of cross-grain and sanding unit, therefore hardly any vibrations on the frame and thus improved sanding quality
- This technology allows window frames to be inserted straight into the machine, which enables the full use of the working width that is so valuable in window construction. At KUNDIG, 1600 mm (63") is a standard working width.
- Very high sanding quality even on cross grain and the transitions between the bars, thanks to our oblique sanding technology





## Practical Examples

Experience the variety and individuality of our special solutions with the following practical examples.



### Portal-Planer-Sandmaschine

This customer planes and sands hard foam boards. With chip removal of up to 20 mm per pass, very high forces are generated. The workpiece must be fixed accordingly. This is done by means of a massive vacuum table, which is moved through the machine on rails. Another advantage of the portal feed is the high precision potential compared to the classic carpet feed. The machine shown here has also been encased in a soundproof cabin.

### Industrial Spraying Line

Our machines are located in the largest production lines in Europe. In this case, we delivered three sanders from our *Technic Perform* range. The sanding systems designed for lacquer sanding work in three shift operations at feed speeds of up to 60 m/min (200 ft/min). The machine shown here, for example, has a throughput of a good 3 million running meters per year.



### Calibration of Brake Discs

A leading manufacturer of automotive high performance brake systems approached us because of our experience in sanding friction linings. We delivered two machines. One for calibrating the carbon fiber discs, another one for the silicon carbide friction lining that is on the disc. The great challenge here is that the material to be sanded is highly abrasive and wears out regular sanding machines very quickly. Our machines run in this environment for many years in continuous operation despite extreme loads. In addition, we supplied handling equipment and a sound-proof cabin on special request.

### High Gloss Lacquer in Concert Piano Production

In the field of high gloss, there is probably no higher discipline than piano lacquer. And the highest form of achievement in this area? Probably the best quality concert pianos in the world. Exactly for such a manufacturer we delivered a lacquer edge sander from our Flash series, as well as a high gloss wide belt sanding machine with our specialized Hg unit and 1900 mm (75") working width. This allows for machine-production of a high-gloss effect, which previously could only be achieved manually and with a great deal of effort and time.



### Bottom-Top Processing of Workpieces in Furniture Industry

This machine is used in the large scale furniture industry for processing continuous MDF. The MDF is brushed from below and sanded from above to prepare for subsequent gluing and laminating. The upper side is finely sanded by two diagonal sanding units located in separate upper machine heads. In order to avoid stopping the 3-shift continuous operation of the production line, one machine head can be lifted off while the other is in operation. Furthermore, this *Technic Perform* is equipped with our *Eco Cleaning System* for workpiece and abrasive belt cleaning without compressed air consumption. Thanks to a sophisticated extraction system, this sander complies with strict „Zero Dust“ requirements. On customer request it was painted in a special color.



### Cork Sanding from Spindle

On this machine of the **Technic Precision** series, one of the largest cork product manufacturers is sanding cork sheets 0.5 mm - 20 mm thick for various applications. The challenges are manifold. Rewinding and unwinding must be perfectly synchronized with the sanding process. The tolerances are only  $\pm 0.02$  mm over a working width of 2200 mm.

### Calibration of Rubber Belts

This is a classic custom tailored project. With this semi-automatic machine, rubber belts are calibrated with high precision. The tolerances are within the range of  $\pm 0.01$  mm.



### Sanding Brass Veneer Edges

This interior fitting company sands the edges of their brass covered MDF boards using a KUNDIG **Flash**. The lacquer edge sander **Flash** has a very low heat development due to its adjustable sanding belt speed and the large oscillation path, thus allowing these parts to be sanded without the adhesive on the relatively small contact area losing its strength due to the heat being generated.

### Bottom-Top Sanding of XXL Butcher Blocks

On this 7-unit top-bottom wide belt sanding machine of our **Technic Botop** model range, the surface of massive butcher blocks is finished in one sanding cycle. The workpiece dimensions: Up to half a meter high and weighing half a ton. On planing rollers, the height offset between the end-grain sticks is equalized on both sides. After that, fine sanding is carried out on contact rollers and sanding pad units. The customer has reduced the time needed to process his butcher blocks from about 3 hours to less than a minute.



## Materials that are processed with our Sanding Machines



#### Wood

Of all kinds. Chip boards, veneer, solid, etc.

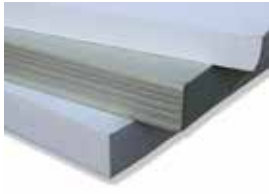

#### Construction Material

Various insulation and foam materials



#### Friction Linings

Different brake- and clutch components



#### Metals

Copper, brass, steel, aluminum etc.



#### Plasterboards

And various minerals / stones

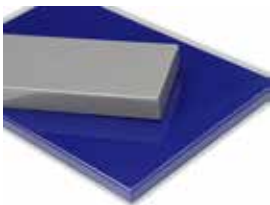

#### Lacquered Parts

All kinds of lacquer types. Polyester, water based etc.



#### Composites

Composite materials of any kind



#### Laminates

HPL, CPL etc.



#### Plastics

Different sorts of plastics



#### Leather

Single pieces or endless (from spindle)



#### Carbon Fiber

For medicinal tech., automotive, aviation etc.



#### Cork

Single pieces or endless (from spindle)



#### Foam Glass Gravel

And other insulating materials



#### Automotive Interiors

Mostly veneer, often bottom/top calibration



#### Honeycomb-Materials

Sandwich panels and other lightweight materials

# Accessories for our Wide Belt Sanders

## Working Table Extensions

A variety of handling and working tables is available in different sizes, with a range of slide surfaces and rollers, as well as in folding or fixed versions.



## Conveyor Belts

- A selection of conveyor belts in various materials, thicknesses and perforations is available.
- A motorized brush can be attached for the purpose of cleaning the feed belt.



## Table Vacuum

- A table vacuum for the securing of workpieces is standard on machines with oblique sanding technology. For all other models it is available as an option
- The small parts vacuum is suitable for sanding particularly small or difficult to fix workpieces.



## Pressure Beams and Guide Plates

Depending on the requirements, a number of pressure beams can be delivered. Guide plates are also available:

- Divided, segmented pressure beam at the inlet
- Floating, sprung pressure beam
- Rigid pressure beam



## Belt Change Aid

Especially for units with long sanding belts or large working widths, the practical belt insertion aid device is of use.



## Texturing Brush

Texturing brush unit mounted at the machine outlet. This is available with brushes in different versions, as well as with motorized or manual height adjustment mechanism.



## Extra Passage Height

The passage height of our sanding machines can be extended from 200 mm (8") to up to 800 mm (32") in order to sand very thick workpieces, such as purlins.



## Feed reversal function

With heavy workpiece weights, handling can quickly take up more time than the sanding process itself. If several sanding passes are required on one part, the practical feed reversal function makes things much easier. A button on the machine output moves the workpiece back to its starting position in the same way.



## Sanding Belt Cleaning

We offer two types of sanding belt cleaning systems, typical air jet belt blow off and our **Eco Cleaning System** which doesn't require the use of compressed air.



## Workpiece Cleaning

We offer a range of devices for cleaning of workpieces

- Rotating air jets using compressed air
- **Eco Cleaning System**, no compressed air required
- Dust brush (horse hair)
- Ionization device to eliminate static charge



Watch **Video** now



[kundig.com/edges](https://kundig.com/edges)



Our **Edge Sanders** have proven themselves in countless companies around the world thanks to their unsurpassed versatility and ease of use. For professionals, they represent an investment with vision, which promises edge processing of the highest quality even after decades of use.



The **Uniq** series is regarded as a fully-fledged basis of our product range and shares all the features that have helped the KUNDIG edge sanding machine earn its reputation in the market as a robust, versatile precision instrument. Part of its extremely solid construction is the motorized oscillating sanding unit, which offers a maximum oscillation path of 90 mm (3.5") and the possibility of motorized tilting by up to 45°. All common edge processing operations can be carried out at up to four sanding stations.

The **Uniq-S** model has, in addition to the features of the **Uniq**, a feed system integrated into the machine body and is therefore ideally suited for the efficient continuous sanding of small and large batches. Difficult work, such as the production of chamfers, is also made easier for the user thanks to the fixation by means of an upper pressure beam.

The **Flash** is specially designed for edge lacquer sanding. With the application-controlled, pneumatic sanding pad, belt blow-off jets and variable sanding belt speed, perfect lacquer sanding is achieved, even on high-gloss lacquered edges. The machine is operated via a touch screen which can be rotated by 270°.

## Model Comparison

	<i>Uniq</i>	<i>Uniq-S</i>	<i>Flash</i>
Four independent sanding stations	●	●	●
Sanding unit inclination between 90 and 45 °	●	●	●
No table height adjustment necessary	●	●	●
Programmable oscillation of sanding unit (10 - 90 mm oscillation range)	●	●	●
Abrasive belt tracking control device	●	●	●
Rotating fence with scale at rear sanding station	●	●	●
Precise stock removal adjustment with scale	●	●	✘
Integrated conveyor system with variable feed speed	✘	●	●
Steplessly variable sanding belt speed	◆	◆	●
Action controlled sanding pad, necessary for lacquer applications	✘	✘	●
Adjustable sanding pad pressure, i.e. for high gloss applications	✘	✘	●
Air jet abrasive belt cleaning device, necessary for lacquer sanding	✘	✘	●
PLC controlled 7" rotating industrial grade touch screen	✘	✘	●
Recallable sanding programs	✘	✘	●

Legend:

● = Standard execution

◆ = Option

✘ = not available for this model

# One Sanding Unit, up to **4 Sanding Stations**



Sanding station 1 is used on the *Uniq* and *Uniq-S* for precise calibration and finish sanding. It functions according to the principle of a jointer machine: The permanently mounted run-out stop forms the zero line and the sanding pad (with sanding belt) is aligned on it by means of a hand knob. The desired stock removal is achieved by resetting the infeed stop against the zero line. The operator can easily adjust this by means of a turning lever and parallelogram mechanism. Since the stops and the sanding pad are parallel to each other at all times, rounding off workpiece corners is impossible. The solid worktable is lined with sliding strips.

This station is ideally suited for sanding flat, angled, beveled or externally rounded workpieces. Here too, the entire sanding unit oscillates. The belt runs over the entire width over a graphite surface that keeps it cool. Sanding with the unit in an inclined position is possible on this side as well. The solid wood side is particularly suitable for producing angles and chamfers. A miter fence is also found here. This allows precise miters to be sanded or even produced.



## **Oscillation Range between 10 (0.4") and 90 mm (3.5")**

Whereas in conventional edge sanding machines the sanding belt oscillates by tilting the belt rollers and therefore table height has to be manually adjusted for even use of the abrasive belts, with KUNDIG, the entire sanding unit moves up and down, driven by a separate motor. Both the huge oscillation path of up to 90 mm as well as the oscillation range can be defined simply by using a set of three buttons. This keeps heat development on the sanding belt low and wear and tear can be comfortably distributed over the entire sanding belt. Tedious table readjustment is completely unnecessary. On a KUNDIG, the work tables are fixed and thus also less prone to vibration, which results in an even more precise sanding process.

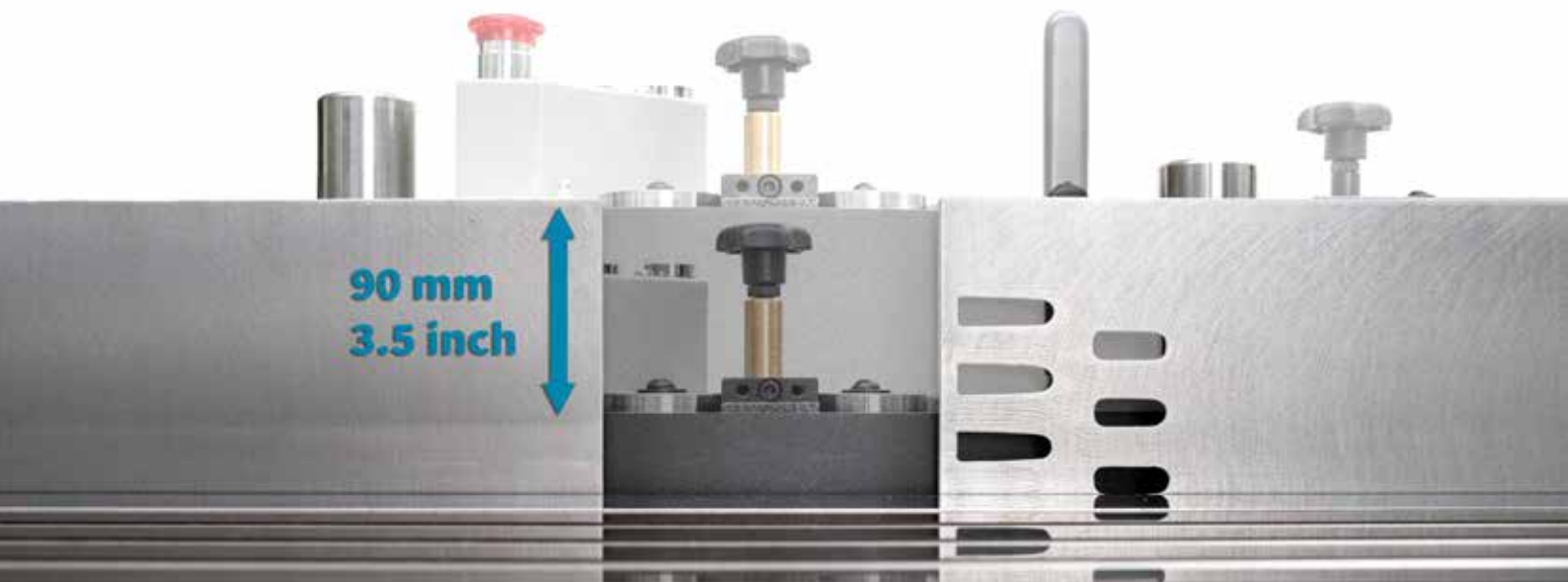

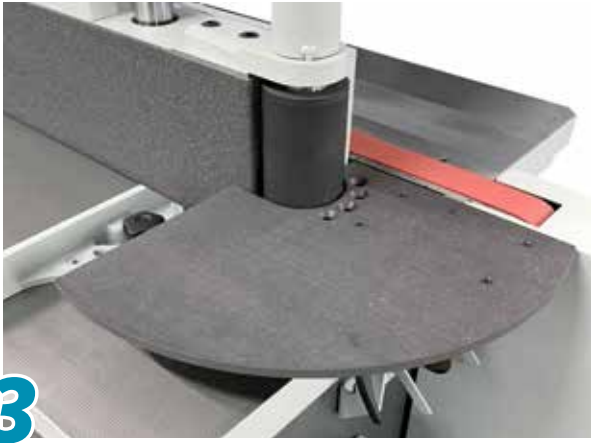

On the optionally available semi round table, curved parts can be precisely sanded using the rubber drive roller. The semi round table is folded up and connected to the dust extraction system in a matter of seconds. On our edge sanding machines the sanding happens at the drive roller. Therefore, a one hundred percent squareness with the workpiece is always guaranteed. This is in contrast to other models where the deflection roller is used for this purpose, which is always slightly tilted for oscillation or belt centering. The large oscillation range of maximum 90 mm (3.5") also applies to this sanding station.

With the optionally available extra table, very fine internal roundings and holes in workpieces can be sanded. The solid aluminum table is quickly mounted and can be attached to the side of the edge sanding machine when not in use. There are holes in the extra table for dust removal. As the abrasive mandrel is part of the sanding unit, you also benefit here from the precise angular adjustment and the large oscillation range. The mandrel can be equipped with abrasive bobbins of different diameters:

- Ø 25 mm (1"), Ø 30 mm (1.2"), Ø 40 mm (1.6")
- Ø 45 mm (1.75") x 100 mm (4")



### ***Sanding Unit Inclination between 45° and 90°***

The sanding unit can be inclined between 90° and 45° using a rotary switch. The exact angle is shown on a scale. This allows sanding at the front as well as the rear station and chamfered and angled edges to be produced. Thanks to the innovative inclination mechanism and the different table heights, the distance between the machine table and the unit always remains at a minimum. The large oscillation range of up to 90 mm (3.5") can also be fully utilized at any sanding unit angle.

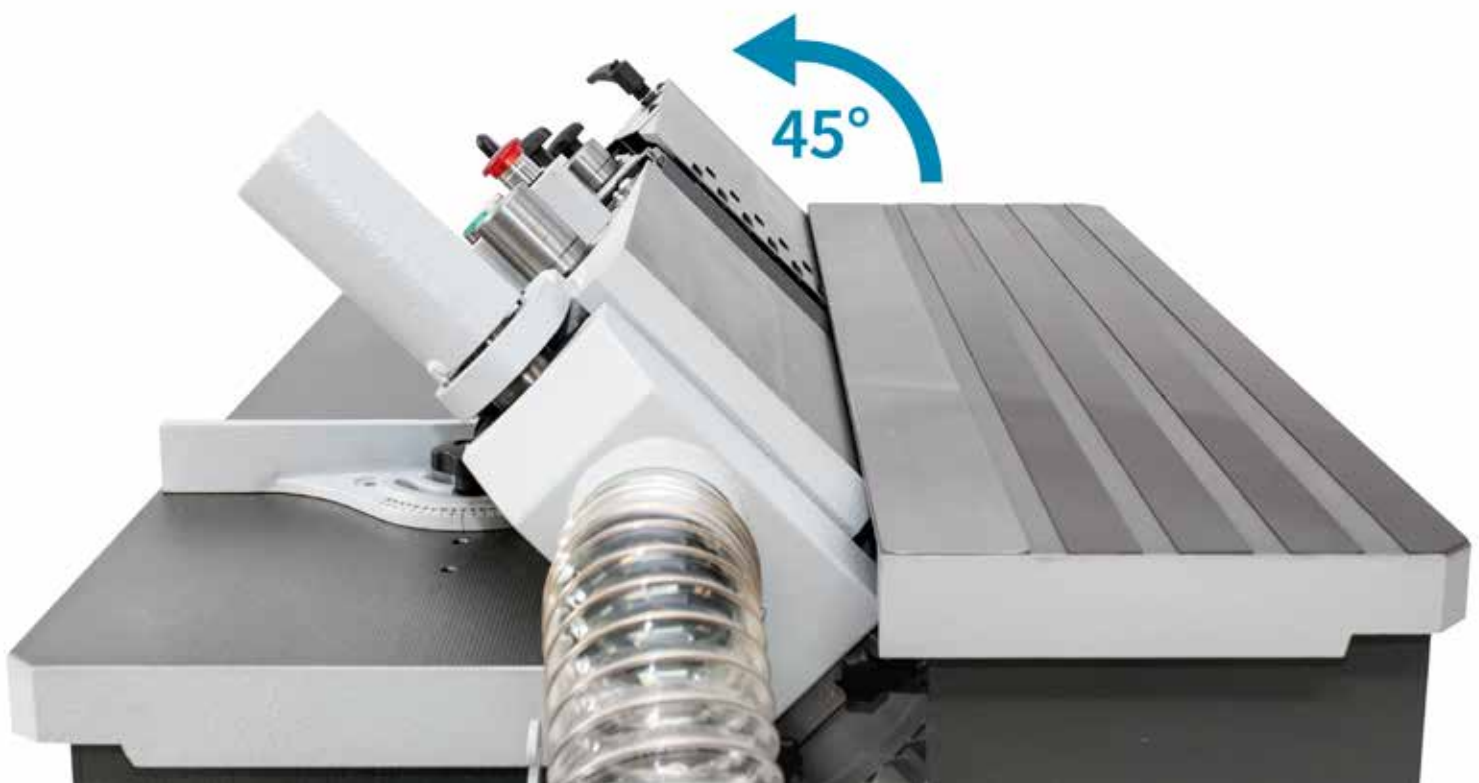



## The Uniq-S and Flash Feed System

The conveyor system distinguishes the *Uniq-S* from the *Uniq*. The motor-driven, rubberized feed belt is integrated in the machine body. The speed can be regulated between 3 - 15 m/min (10 - 50 ft/min). This system is ideally suited for continuous sanding of workpieces of the same thickness. Furthermore, it offers excellent support for sanding operations that usually require a great deal of sensitivity, such as the creation or sanding of chamfers or angled edges. All these sanding operations are also possible with the *Uniq* model, but the feed offers a help that you don't want to miss anymore once you have it. A number of options are available for the *Uniq-S* feed system. With our *Flash* model these features are standard (see below).

## KUNDIG *Flash* for lacquered Edges up to High Gloss

The *Flash* is hardly comparable with any other edge sanding machine. It was developed for sanding of lacquered edges up to high gloss and is in many regards very similar to a lacquer wide belt sander.

### Sanding Belt Cleaning Device

The standard dust extraction system is sufficient for regular edge sanding work. However, lacquer dust is stubborn and accumulates especially in the finely-grained sanding belts, which are needed for lacquer sanding. That is why the *Flash* is equipped with highly efficient belt blast nozzles, which keep the sanding belt clean and also help with cooling.



### Fully equipped Feed System

For the transport of delicate lacquer parts, the *Flash* is equipped ex works with the fully loaded feed system. Two parallel, rubber-coated feed belts transport the workpieces gently and safely past the sanding station. Furthermore, the pressure beam is also equipped with a rubberized conveyor belt, which not only protects the workpieces but also helps when sanding extremely small parts.

### Adjustable Sanding Belt Speed

Both the *Uniq-S* and the *Flash* are equipped with variable feed speed. In order to adjust the sanding exactly to the properties of different lacquer types, the *Flash* also has a variable sanding belt speed.





### Rotating Touch Screen

Most functions of the **Flash** are controlled via the touch screen which can be rotated through 270°. This is ideal for adjusting the insertion and removal of the pneumatic sanding pad. Also the oscillation, sanding belt and feed speed, as well as the inclination of the sanding unit can be adjusted easily. The **Flash** also offers the possibility of storing and recalling sanding programs.

### Action Controlled Pneumatic Sanding Pad

Similar to a wide belt sanding machine for lacquer, the **Flash** has an action-controlled sanding pad. Its insertion and removal (see above) can be accelerated and delayed using the touch screen to achieve a perfect finish without damaging the sensitive, thin lacquer coating, especially in the corner area. The sanding unit also offers the possibility of exchanging sanding pad inserts.

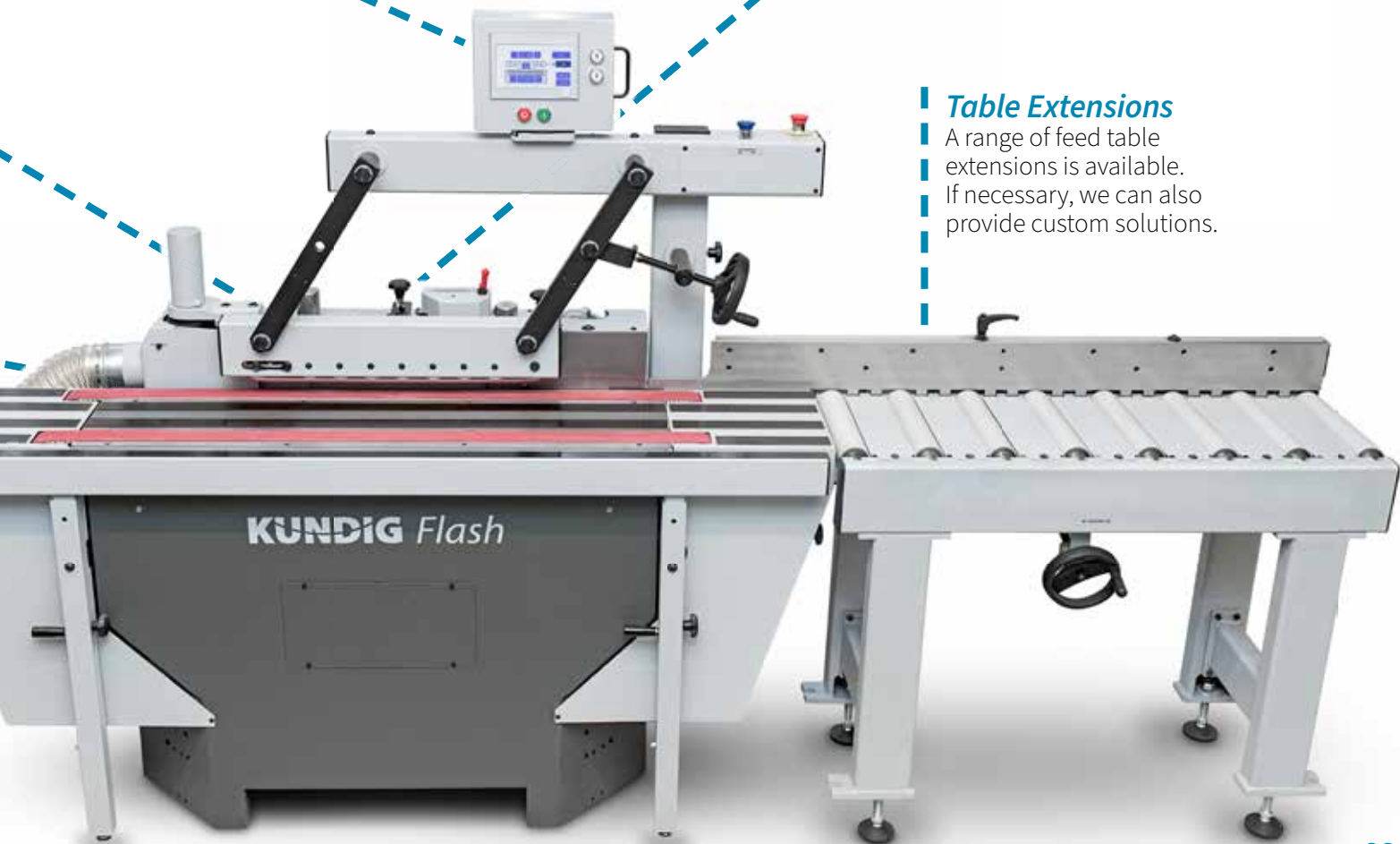

### Table Extensions

A range of feed table extensions is available. If necessary, we can also provide custom solutions.

# Accessories for our Edge Sanders



## Machine Mobile

Increased flexibility and mobility thanks to four transport wheels



## Telescopic Support Rail

Helps with processing of large workpieces. Steplessly extendable up to 900 mm, lockable. Surface with slide lining. Feet with level adjustment.



## Semi round Table

400 x 500 mm for sanding curved or rounded parts at the rubberized drive roller. Folding and ready for use within seconds



## Extra Table

for sanding fine curves and recesses with sanding sleeves in different diameters. Attachable and ready for use in seconds.



## Support fence 45°

Ensures a straight stop with the sanding unit set at an angle of 45° and thus helps to produce perfectly chamfered edges.



## Grooved Inlet Platen

The grooved inlet platen allows the sanding of edges with overlapping veneers

## Uniq Uniq-S Flash



## Steplessly variable Sanding Belt Speed

For sensitive surfaces and materials that have a low melting point, the *Uniq* and *Uniq-S* models can also be equipped with variable sanding belt speed. It is standard in the *Flash* model



## Dust extraction tube

This option is recommended for workshops with a ceiling mounted dust collection system. The metal tube is designed so that the exhaust is never in the way during sanding. Available with slider mechanism (open / closed).

## Uniq Uniq-S

## Uniq-S Flash

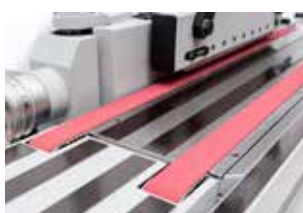

## Second parallel Feed Belt

For extra wide or extra sensitive workpieces an additional lower feed belt can be provided.



## Upper Feed Belt

Replaces the standard pressure rollers of the *Uniq-S* model. The upper feed belt facilitates the sanding of smaller components.

## Uniq-S

# Lifelong enjoyment of your **KUNDIG**

## Customer care and Service

At Kündig, professional support for our customers is our top priority. This begins with the individual needs analysis during the purchasing process and continues with the training during commissioning. Of course, we are also available to provide advice and support after the purchase. Investing in a Kündig sanding machine establishes a long-term partnership in which we provide you with professional and comprehensive support.

Kündig Service will help you with any questions you may have about your sanding machine. If a problem occurs despite the high reliability of our machines, our competent customer service will deal with it immediately. The control unit offers the option of direct remote access to your Kündig by a technician. Most issues can be solved in this way.

Otherwise, our trained service staff will be on site as quickly as possible.

By the way: A Kündig should primarily be a future-proof investment. That's why long-term availability of spare parts is a matter of course for us.



Training on the new KUNDIG: Demonstration of the graphite cloth.



## Kündig worldwide

With two production sites, four sales companies and numerous partners, we are close to our customers in our main markets.





[kundig.com](http://kundig.com)



**International**

Kündig AG  
Hofstraße 95  
CH-8620 Wetzikon  
Tel +41 434773001

[info@kundig.com](mailto:info@kundig.com)  
[www.kundig.com](http://www.kundig.com)



**Deutschland**

Kündig GmbH  
Kindleber Straße 168  
D-99867 Gotha  
Tel +49 36218786-100

[info@kundig.de](mailto:info@kundig.de)  
[www.kundig.de](http://www.kundig.de)



**Österreich**

Kündig GmbH  
Sternsteinstraße 11  
A-4191 Vorderweißenbach  
Tel +43 721970170

[info@kundig.at](mailto:info@kundig.at)  
[www.kundig.at](http://www.kundig.at)



**France**

Kündig Sàrl  
Le Gardot 17  
F-25500 Montlebon  
Tel +33 381674264

[info@kundig.fr](mailto:info@kundig.fr)  
[www.kundig.fr](http://www.kundig.fr)



**England**

Kündig Ltd.  
Unit 4a, Dakota Way  
Burscough, L40 8AF  
Tel +44 8458330565

[info@kundig.co.uk](mailto:info@kundig.co.uk)  
[www.kundig.co.uk](http://www.kundig.co.uk)



**USA**

Kündig Inc.  
PO Box 235  
Wabasso, MN 56293  
Tel +1 612.355.7150

[info@kundig.us](mailto:info@kundig.us)  
[www.kundig.us](http://www.kundig.us)